

H300 Series

General-Purpose Vector Frequency Inverter

H300 is a high-performance general-purpose vector frequency inverter capable of controlling both asynchronous motors and PM synchronous motors.

It features bus communication functionality, background software monitoring, robust functionality, and stable performance. Suitable for applications in textile machinery, plastic machinery, packaging machinery, mining machinery, HVAC, machine tools, as well as various automated production equipment.



Supports Multiple Motor/Load Types

H300 can drive standard three-phase asynchronous motors, inverter-duty motors, PM synchronous motors (PMSM), torque motors, linear motors, etc., meeting diverse customer requirements.

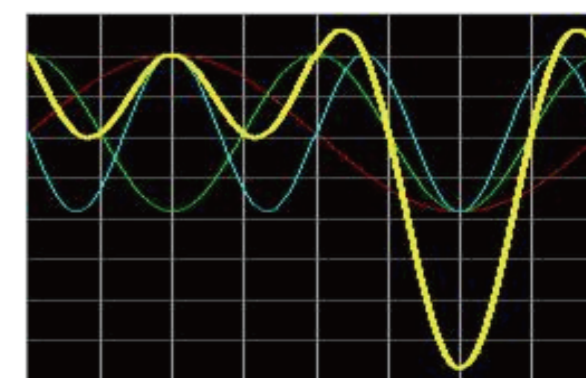

Wide Voltage Design

Input voltage: 380 ~ 480 VAC, permissible fluctuation range: -15% ~ +10% (323 ~ 528 VAC). Ensures reliable operation despite voltage fluctuations, suitable for demanding grid environments.



Multiple EMC Specifications and Solution

Incorporates floating ground design. Grounding or floating can be quickly selected via terminals, effectively resolving EMC interference issues.



Background Software Monitoring

Facilitates computer-based parameter management of the drive. Rich background monitoring functions and online oscilloscope functionality enable more convenient and rapid commissioning and monitoring of field-installed drives.



Software Suppression Functions

Supports under-voltage suppression, over-voltage suppression, and over-current suppression. Enhances system stability and extends equipment service life.



Powerful Expansion Capabilities

Multiple extension interfaces to meet customized needs. Standard Modbus RTU communication, compatible with optional communication protocols such as PROFIBUS-DP, CANopen, EtherCAT, PROFINET, Modbus TCP, etc.

H300 Nameplates and Naming Rules

DELIXI ELECTRIC

Reference: H300G18R5P22T4B
 Input: AC 3PH 380V~480V 42/51A 50/60Hz
 Output: AC 3PH 0V~480V 37/45A 0~599Hz 18.5/22kW

Hardware Version: 1.0.01 Software Version:1.01
 SN : G18R5P22T4B25B000001



DELIXI HANGZHOU INVERTER CO.,LTD.



Product Selection

Type	Appearance structure	Heavy load type				Light load type				BRAKE UNIT
		Power capacity (kVA)	Input current (A)	Output current (A)	Adapt motor (kW)	Power capacity (kVA)	Input current (A)	Output current (A)	Adapt motor (kW)	
Three phase 380~480V, 50/60Hz										
H300G0R4P0R75T4B	SIZE1	2	2.2	1.6	0.4	2.8	4.4	3	0.75	standard configuration
H300G0R75P1R1T4B		2.8	4.4	3	0.75	4.1	5	3.5	1.1	
H300G1R1P1R5T4B		4.1	5	3.5	1.1	5	6	4.5	1.5	
H300G1R5P2R2T4B		5	6	4.5	1.5	6.7	6.8	6	2.2	
H300G2R2P3R0T4B		6.7	6.8	6	2.2	9.5	9	7.5	3	
H300G3R0P4R0T4B		9.5	9	7.5	3	12	11	9.5	4	
H300G4R0P5R5T4B	SIZE2	12	11	9.5	4	17.5	15.5	13	5.5	Optional
H300G5R5P7R5T4B		17.5	15.5	13	5.5	22.8	20.5	17	7.5	
H300G7R5P11T4B	SIZE3	22.8	20.5	17	7.5	33.4	26	25	11	
H300G11P15T4B		33.4	26	25	11	42.8	35	32	15	
H300G15P18R5T4B	SIZE4	42.8	35	32	15	33	38.5	37	18	
H300G18R5P22T4(B)	SIZE5	33	38.5	37	18.5	39	46.5	45	22	
H300G22P30T4(B)		39	46.5	45	22	52	62	60	30	
H300G30P37T4(B)	SIZE6	52	62	60	30	63	76	75	37	
H300G37P45T4(B)		63	76	75	37	79	92	90	45	

*Note: The parentheses in the model indicate optional accessories

Naming rules

H300
G18R5P22
T4
B

①
②
③
④

SN	Field	Description
①	Product series Number	H300: H300 series
②	Product type and power	G: Heavy load 18R5: It indicates the power of applicable motor is 18.5kW
		P: Light load 22: It indicates the power of applicable motor is 22kW
③	Voltage grade	T4: 3-phase 380V~480V, AC, 50/60Hz
④	Braking unit	Null: No
		B: Built-in braking unit

Note:
 ● 3-phase 380V~480V, braking unit is configured for SIZE1~SIZE4 and is optional for SIZE5~SIZE6.

Technical specifications

Control performance

Type of drivable motors		Asynchronous induction motor (IM), permanent magnet synchronous motor (PMSM)
Control mode		Open-loop vector control (SVC), V/F control
Asynchronous machine VF	Supported functions	overvoltage suppression, overcurrent suppression, voltage sag suppression, oscillation suppression, torque boost, slip compensation, selection of different VF curves, VF separation, DC braking, random PWM, overexcitation fast deceleration, sag control
	Supported functions	Master slave control, overvoltage suppression, DC braking, torque control, instant stop without stop, parameter self-learning, speed tracking, etc
Asynchronous machine SVC	Speed regulation range	1:250 (SVC)
	Starting torque	0.25Hz/150% (SVC)
	Torque step response	Torque step response within 2ms
	Torque control accuracy	Torque control accuracy is ±3% above 5Hz
	Velocity stability accuracy	0.05%
	Weak magnetism rate	5 times of weak magnetism
Synchronous machine SVC	Supported functions	Master slave control, overvoltage suppression, DC braking, torque control, instant stop without stop, parameter self-learning, speed tracking, etc
	Speed regulation range	1:100 (SVC)
	Starting torque	0.5Hz/150% (SVC)
	Torque step response	Torque step response within 2ms
	Torque control accuracy	Torque control accuracy is ±3% above 5Hz
	Velocity stability accuracy	0.05%

D Technical specifications

Basic functions

Command channel		Command channel Control motor start/stop, etc., including DI/DO, virtual DI/DO, external expansion card DI/DO, support switching of 4 groups of different motor parameters and control parameters, support free programming and setting of start/stop command
Given channel	Input frequency resolution	Figure setting: 0.01Hz Simulation setting: Max. frequency ×0.1%
	Given velocity/torque	Acceleration/deceleration curve, dynamic switching between multiple groups of acceleration/deceleration time, acceleration/deceleration S curve, given external PID, AI (2-way, support ±10V, 0~20mA), given communication speed and torque, given pulse (HDI1), Multiple speed settings, etc., support free programming and velocity setting/given torque
Communication mode		Support 7 communication modes: Modbus (Modbus-RTU, Modbus-TCP) 、 Profibus-DP、 CAN 、 CANopen、 Profinet、 EtherCAT、 4G-LTE
Output limitation		Support torque limitation, power limitation, current limitation, limit torque limitation, velocity limitation and frequency hopping
Process control	PID	Free configuration of sleep, given and feedback source, switching of 2-segment PID parameters, feedback loss detection, free configuration of output limitation, free initialization configuration
Protection		Inverter motor protection, including overvoltage, overcurrent, overload, motor overheat (PT100, PT1000, KTY 84 130), load drop protection, fault auto reset, auto reboot, etc.,

Personalized function

Free programming	Realize free programming. Support word bit conversion, single/double word conversion, logic (AND-NOR, XOR), Arithmetic operation (fixed-point and floating-point add, subtract, multiply and divide, absolute value, numeric comparison), selector switch, free filtering, logic delay on/off, multi-point curve, constant value
Self-detection	Inverter and motor detection. Support detection of IGBT straight connection, short circuit to ground, phase loss self-detection, encoder self-detection, inter-phase short circuit self-detection
background software	Background software Dlx.DriveStudio supports parameter upload/download and oscilloscope function of inverter. Support remote debugging and fault diagnosis through background software. Monitor internal status of the Product through oscilloscope

Running

Running instruction	Given by operation panel, given by control terminal, given by serial communication port (switched through different modes).
Frequency instruction	14 frequency instructions: Given by figure, given by analog voltage, given by analog current, given by pulse, given by serial port (switched through different modes)
Auxiliary frequency instruction	14 auxiliary frequency instructions. Flexibly realize fine tuning and synthesis of auxiliary frequency.
Input terminal	Standard: 4 DI terminals, 1 HDI terminals 2 AI terminals, AI1 supports 10V~10V voltage mode input, AI2 supports 10V~10V voltage mode input, 0~20mA current mode input.
Output terminal	Standard: 1 AO terminals, support 0~10V voltage output or 0~20mA current output 1 relay output terminals

D Technical specifications

Display and keyboard Operation

Display of LED operation panel	Display and modify parameters, display inverter status (forward rotation/reverse rotation/shutdown, panel/terminal/communication control, velocity/torque control, STO status, etc.)
Copy parameters	Realize fast upload/download of parameters through optional LCD operation panel
Button lock and function selection	Lock buttons partially and define the action scope of some buttons, to prevent maloperation

Environment

Application scenario	Indoor, free from direct sunlight, dust, corrosive gas, flammable gas, oil mist, water vapor, dropping water or salt, etc.
Altitude	No derating below altitude of 1,000m; derated by 1% when height increases by 100m above the altitude of 1,000m; the max. service altitude is 3,000m. Please contact the manufacturer when altitude exceeds 3,000m (Note: The max. service altitude for SIZE1-structured inverter is 2,000m; please contact the manufacturer when the altitude exceeds 2,000m)
Ambient temperature	-10°C ~ +50°C, have derated use when the ambient temperature is 40~50°C; derated by 1.5% when the ambient temperature increases by 1°C.
Humidity	Below 95%RH, no condensation.
Vibration	Below 5.9m/s ² (0.6g)
Storage temperature	-20°C ~ +65°C



D Control class extension options

Name		Model	Description
operation keyboard	LED (with button) keyboard	/	LED (with button) keyboard
I/O expansion card	HEEIO1	HEEIO1	4-way DI + 1-way AI + 1-way DO + 1-ray relay output + CAN+ RS485 (Applicable to 15kW and higher model)
	HEEIO2	HEEIO2	3-way DI
	HEEIO3	HEEIO3	3-way DI + 1-way relay + RS485
	HEEIO4	HEEIO4	3-way DI + 1-way DO + 1-way relay
	HEEIO5A	HEEIO5A	4-way DI + 2-way DO + RS485
	HEEIO5B	HEEIO5B	4-way DI + 2-way DO
	HEEIO6	HEEIO6	1-way AI (support differential voltage input and temperature detection resistance input)
HEEIO7	HEEIO7	1-way AI (Supports -10V DV~10V DC input)	
Communication expansion card	CANopen communication card	HEECANOPEN	CANopen
	PROFIBUS communication card	HEEDP	PROFIBUS
	PROFINET communication card	HEEPN	PROFINET
	EtherCAT communication card	HEECAT	EtherCAT
	4G communication card	HEE4G	LTE
	TCP communication card	HEETCP	MODBUS—TCP Slave Protocol
	CAN communication card	HEECAN	CAN2.0B Protocol
RS485 communication card	HEE485	MODBUS-RTU Slave	

D Selection of brake components

Inverter Model	Brake Unit Model	125% braking torque (10% ED, maximum 10 seconds)		Minimum Resistance of braking resistor (Ω)
		Resistance of braking resistor (Ω)	Braking resistor power (W)	
H300G0R4P0R75T4B	Built-in	1450	80	100
H300G0R75P1R1T4B	Built-in	800	140	100
H300G1R1P1R5T4B	Built-in	500	220	100
H300G1R5P2R2T4B	Built-in	380	300	100
H300G2R2P3R0T4B	Built-in	260	440	65
H300G3R0P4R0T4B	Built-in	190	600	65
H300G4R0P5R5T4B	Built-in	150	740	35
H300G5R5P7R5T4B	Built-in	100	1100	35
H300G7R5P11T4B	Built-in	75	1500	35
H300G11P15T4B	Built-in	50	2200	25
H300G15P18R5T4B	Built-in	38	3000	25
H300G18R5P22T4(B)	Optional built-in, External CDI-BR-50	30	4000	25
H300G22P30T4(B)	Optional built-in, External CDI-BR-50	30	4000	25
H300G30P37T4(B)	Optional built-in, External CDI-BR-50	20	6000	20
H300G37P45T4(B)	Optional built-in, External CDI-BR-100	16	9000	15

D Electrical wiring diagram

*Note: Applicable to SIZE1~SIZE6 models

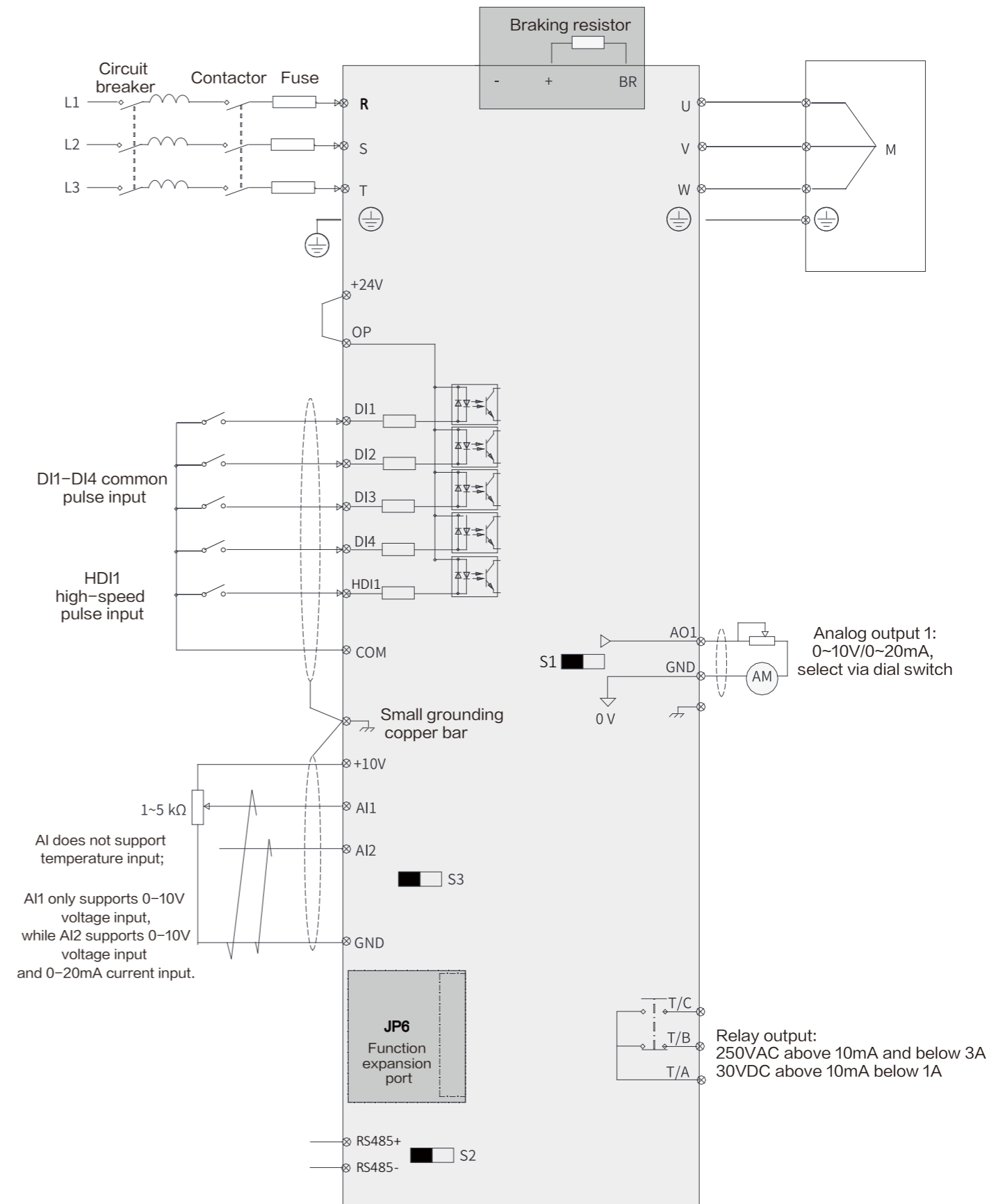

D Distribution of Control Circuit Termina

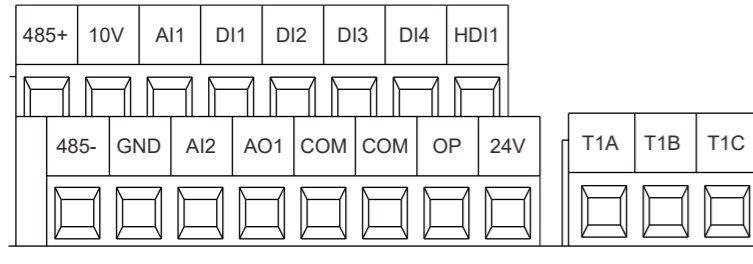
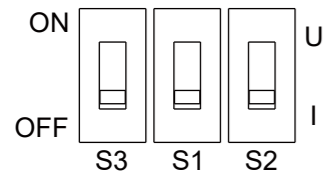

D Appearance and installation dimensions

(Unit: mm)

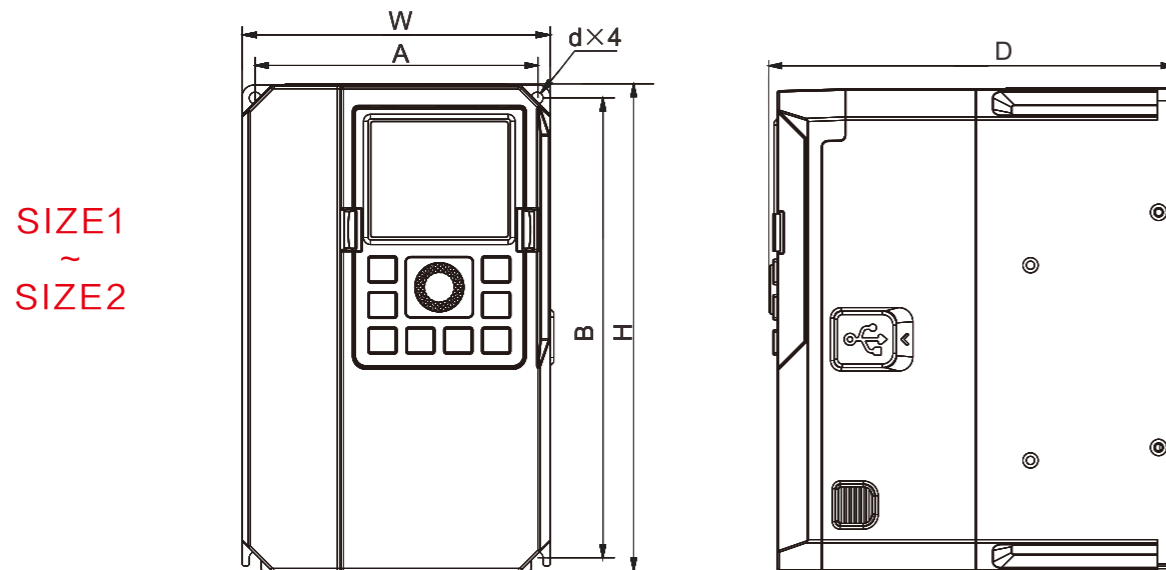

SIZE1
~
SIZE2

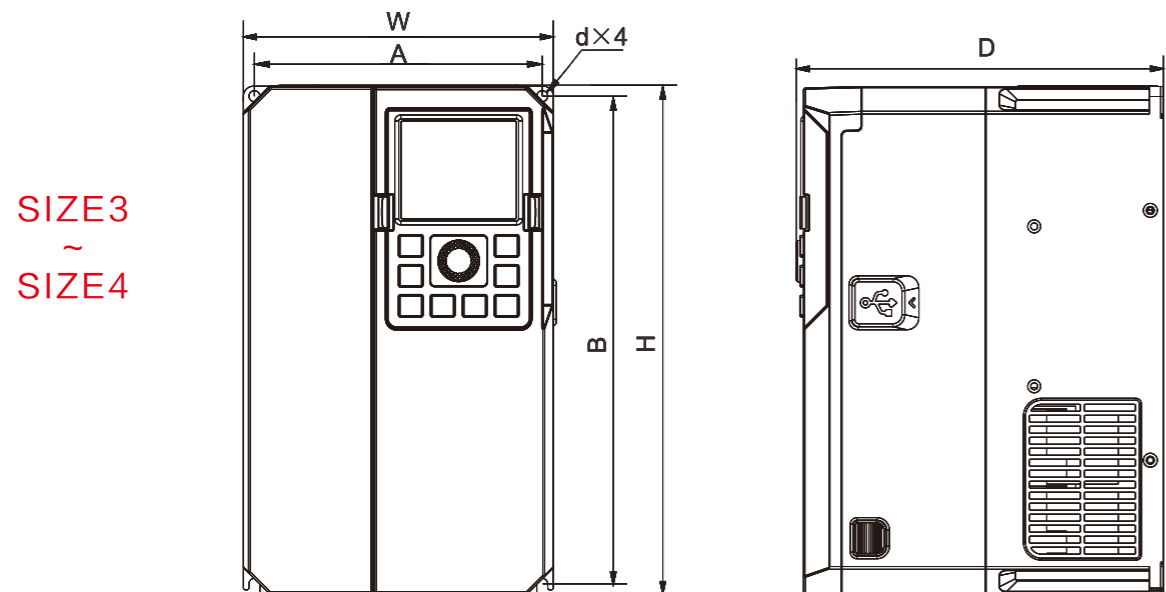

SIZE3
~
SIZE4

D Appearance and installation dimensions

(Unit: mm)

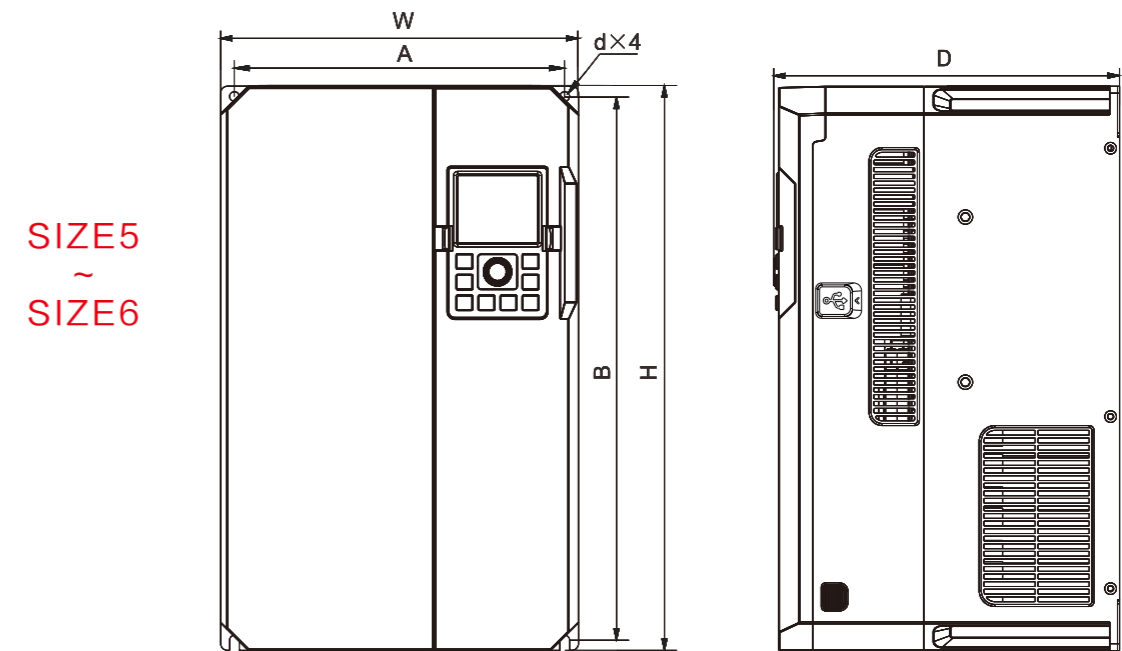

SIZE5
~
SIZE6

Appearance structure	Mounting hole (mm)		Outline dimensions (mm)			Installation hole diameter (mm)
	A	B	H	W	D	d×4
SIZE1	119	194	205	130	160	Ø5
SIZE2	119	194	205	130	170	Ø5
SIZE3	144	244	254	155	181.5	Ø5.5
SIZE4	182	275	285	192	181.5	Ø5.5
SIZE5	198	338	350	210	210	Ø5.5
SIZE6	240	395	410	260	248	Ø7

◎ External keyboard opening size

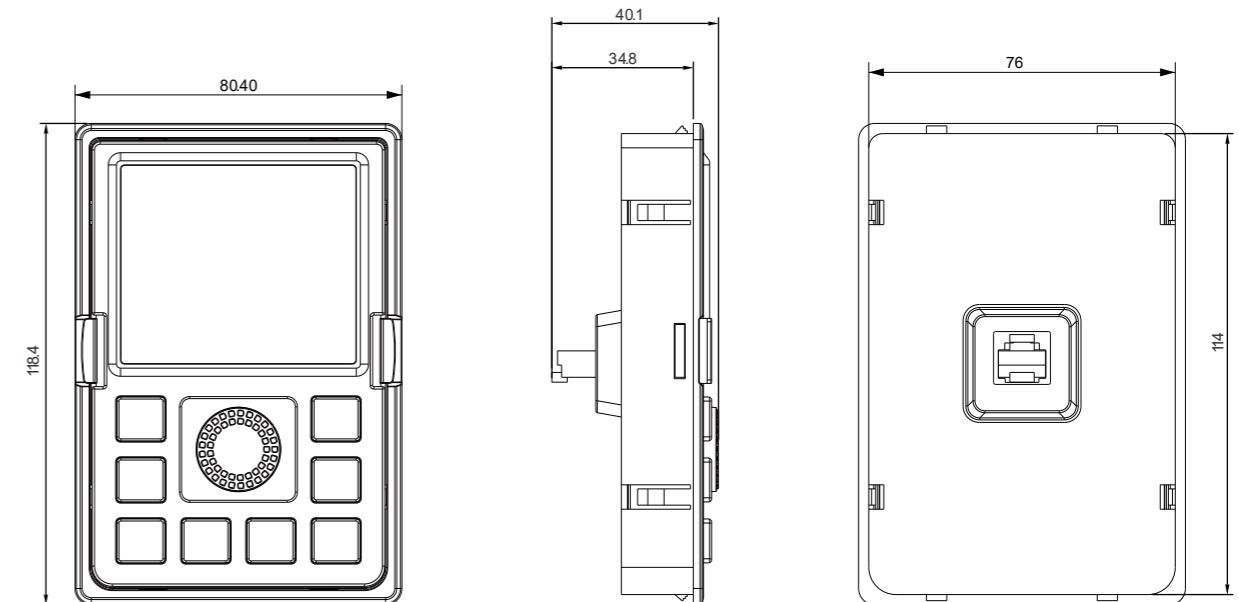

D Introduction to Composition of Onboard Operation Panel

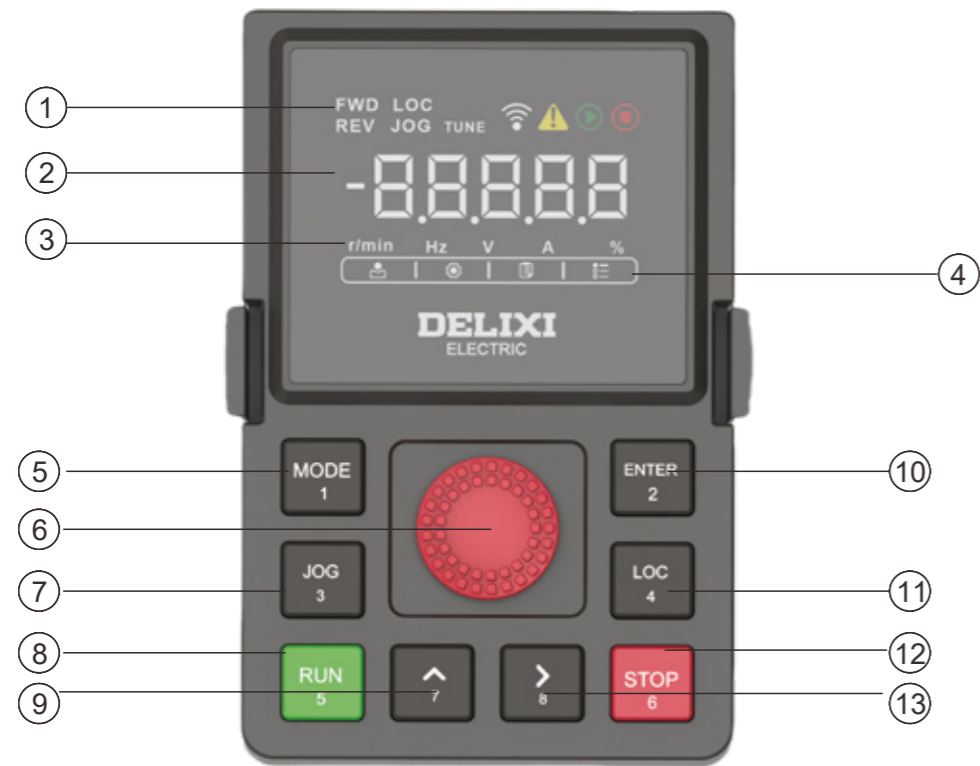

S/N	Part Name	Description
1	Status indicator	Display the forward/reverse rotation status, local and remote, jogging, tuning, alarm and fault, running and shutdown
2	Main display area	Display function code parameters
3	Unit display area	Display the corresponding units of function code
4	Menu display area	Display basic mode, user mode and check mode
5	MODE key	Switch display mode, cancel data modification
6	Keyboard knob	Adjust frequency, modify data, modify function code
7	JOG key	Multi-function key (controlled by function code P0.1.35)
8	RUN key	For starting equipment under local control mode
9	UP key	Frequency increment, data increment, function code increment
10	ENTER key	Read and store the set parameters while setting parameters
11	LOC key	Multi-function key (controlled by function code P0.1.35)
12	STOP key	Stop the equipment while equipment is running. Reset fault when equipment has a fault
13	Right shift key	Switch display data during monitoring; shift the data modification position while selecting and setting parameters

D Application area

